

MONOLITHIC AMPLIFIERS

50Ω

BROADBAND DC to 8 GHz

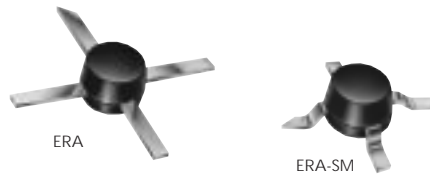

low power, up to +13.5 dBm

all specifications at 25°C

MODEL NO.	FREQ. GHz f _c - f _u	GAIN, dB Typical								MAXIMUM POWER (dBm) at 2 GHz*		DYNAMIC RANGE at 2 GHz*		VSWR (:1) Typ.				ABSO-LUTE MAX. RATING ³		DC OPERATING POWER at Pin 3			THERMAL RESISTANCE	CASE STYLE	CONNECTION	PRICE \$			
		0.1	1	2	3	4	6	8	Min. @ 2 GHz	Flatness DC-2 GHz	Output (1 dB Comp.) Typ.	Input (no dmg) Min.	NF (dB) Typ.	IP3 (dBm) Typ.	In DC-3 GHz	3-f _u ** GHz	Out DC-3 GHz	3-f _u ** GHz	I (mA)	P (mW)	Current (mA)	Volt. Typ	Min	Max	θ _{jc} Typ. °C/W	Note B	Qty. (30)		
ERA-1	DC-8	12.2	12.1	11.8	11.5	11.3	11.0	10.2	9	±0.3	11.7	9.7	15	5.3	26	1.6	1.8	1.5	1.9	75	330	40	3.6	3.0	4.1	455	VV105	cb	1.37
ERA-2	DC-6	16.2	16.0	15.6	15.1	14.6	14.0	—	12	±0.3	12.8	11	15	4.7	26	1.4	1.4	1.4	1.6	75	330	40	3.6	3.0	4.1	455	VV105	cb	1.52
ERA-3	DC-3	22.9	22.2	20.8	19.2	—	—	—	17	±1.1	12.1	9	13	3.8	23	1.7	—	1.7	—	75	330	35	3.5	3.0	4.1	432	VV105	cb	1.67
ERA-1SM	DC-8	12.3	12.1	11.8	11.2	10.8	10.4	9.2	9	±0.3	11.3	9.3	15	5.5	26	1.6	1.9	1.5	1.9	75	330	40	3.6	3.0	4.1	460	WW107	cb	1.42
NEW ERA-21SM	DC-8	14.2	13.9	13.2	12.2	10.8	8.7	8.9	11.2	±0.5	12.6	10.6	15	4.7	26	1.1	1.4	1.3	1.9	75	330	40	3.5	3.0	4.1	194	WW107	cb	1.57
ERA-2SM	DC-6	16.2	15.8	15.2	14.4	13.6	13.0	—	12	±0.5	12.4	10.5	15	4.6	26	1.5	1.6	1.5	1.7	75	330	40	3.6	3.0	4.1	460	WW107	cb	1.57
NEW ERA-33SM	DC-3	19.3	18.7	17.4	15.9	—	—	—	15	±0.9	13.5	11.5	13	3.9	28.5	1.6	—	1.25	—	75	330	40	4.3	3.8	4.8	140	WW107	cb	1.72
ERA-3SM	DC-3	22.8	21.8	20.2	18.4	—	—	—	16	±1.3	11.5	9	13	3.8	23	1.5	—	1.5	—	75	330	35	3.5	3.0	4.1	437	WW107	cb	1.72

features

- miniature microwave amplifier
- available in drop-in & surface mount (sm) versions
- frequency range, DC to 8 GHz, usable to 10 GHz
- up to 18.5 dBm typ. (16.5 dBm min) output power

absolute maximum ratings

operating temperature: -45°C to 85°C
storage temperature: -65° to 150°C

model identification

Model marking (see note below)

ERA-1, ERA-1SM	1
ERA-2, ERA-2SM	2
ERA-21SM	21
ERA-3, ERA-3SM	3
ERA-33SM	33
ERA-4, ERA-4SM	4
ERA-5, ERA-5SM	5
ERA-51SM	51
ERA-6, ERA-6SM	6

Note: Prefix letter (optional) designates assembly location. Suffix letters (optional) are for wafer identification.

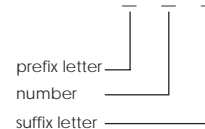

NOTES:

- ◆ Aqueous washable
- * at 1 GHz for ERA 4, 5, 6, 4SM, 5SM, 51SM, 6SM
- ** f_u is the upper frequency limit for each model as shown in the table.
- ⊛ Low frequency cutoff determined by external coupling capacitors.
- A. Environmental specifications and re-flow soldering information available in General Information Section.
- B. Units are non-hermetic unless otherwise noted. For details on case dimensions & finishes see "Case Styles & Outline Drawings".
- C. Prices and Specifications subject to change without notice.
- D. For Quality Control Procedures see Table of Contents, Section 0, "Mini-Circuits Guarantees Quality" article. For Environmental Specifications see Amplifier Selection Guide.
- 1. Model number designated by alphanumeric code marking.
- 2. ERA-SM models available on tape and reel.
- 3. Permanent damage may occur if any of these limits are exceeded.

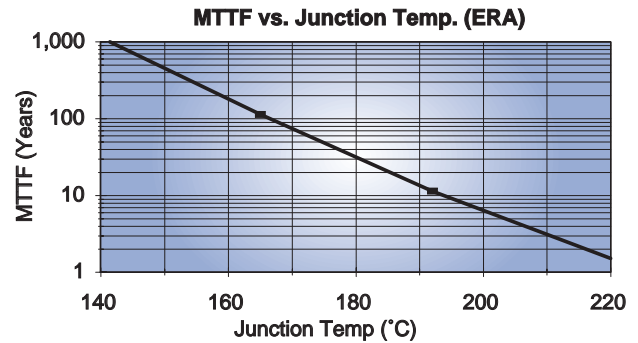

Drop-In & Surface Mount

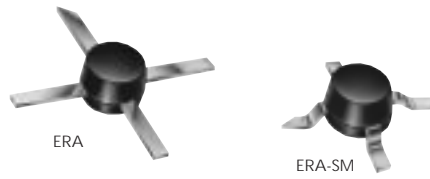

medium power, up to +18.5 dBm output

all specifications at 25°C

MODEL NO.	FREQ. GHz $f_c - f_u$	GAIN, dB Typical								MAXIMUM POWER RANGE at 2 GHz*		DYNAMIC RANGE at 2 GHz*		VSWR (:1) Typ.				ABSOLUTE MAX. RATING ³		DC OPERATING POWER at Pin 3			THERMAL RESISTANCE θ_{jc} Typ. °C/W	CASE STYLE Note B	CONNECTION	PRICE \$ Qty. (30)			
		over frequency, GHz								Output (1 dB Comp.) Typ. Min.	Input (no dmg) Typ.	NF (dB) Typ.	IP3 (dBm) Typ.	In DC-3 GHz	Out 3-f _u ** DC-3 GHz	I (mA)	P (mW)	Current (mA)	Volt.										
		0.1	1	2	3	4	6	8	Min. @ 2 GHz										Flatness DC-2 GHz	Typ.	Min.	Typ.					Typ.	Typ.	Min
ERA-6	DC-4	11.1	11.1	11.3	11.5	11.3	—	—	10	±0.2	18.5	16.5	20	8.4	36.5	1.3	1.3	1.6	1.6	120	850	70	5.2	4.6	5.6	220	VV105	cb	3.85
ERA-4	DC-4	13.8	13.7	13.5	13.3	13.0	—	—	11	±0.2	17.0	15	20	5.5	32.5	1.6	1.6	1.4	1.6	120	650	65	5.0	4.2	5.5	278	VV105	cb	3.85
ERA-5	DC-4	20.2	19.8	18.8	17.7	16.4	—	—	16	±0.75	18.4	16.5	13	4.5	33	1.2	1.2	1.3	1.5	120	650	65	4.9	4.2	5.5	278	VV105	cb	3.85
ERA-6SM	DC-4	11.2	11.2	11.3	11.4	11.2	—	—	10	±0.2	17.9	16	20	8.4	36	1.3	1.3	1.6	1.5	120	850	70	5.2	4.6	5.6	225	WW107	cb	3.90
ERA-4SM	DC-4	14.0	13.8	13.5	13.2	12.7	—	—	11	±0.3	16.8	15	20	5.2	33	1.6	1.6	1.3	1.5	120	650	65	5.0	4.2	5.5	283	WW107	cb	3.90
NEW ERA-51SM	DC-4	18.0	17.4	16.1	14.8	12.5	—	—	14	±1.0	18.1	16.5	13	4.1	33	1.1	1.2	1.2	1.9	120	650	65	4.5	4.2	5.5	154	WW107	cb	3.90
ERA-5SM	DC-4	20.2	19.5	18.5	17.3	16.2	—	—	16	±1.0	18.4	16.5	13	4.3	32.5	1.3	1.3	1.2	1.3	120	650	65	4.9	4.2	5.5	283	WW107	cb	3.90

typical biasing configuration

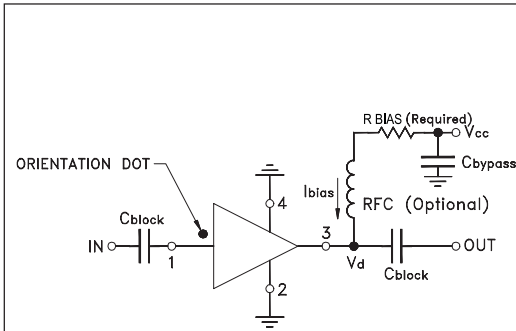

R BIAS "1%" Resistor Values (ohms) for Optimum Biasing of ERA Models									
Vcc	ERA-1 ERA-1SM	ERA-2 ERA-2SM	ERA-2 21SM	ERA-3 ERA-3SM	ERA-3 33SM	ERA-4 ERA-4SM	ERA-5 ERA-5SM	ERA-5 51SM	ERA-6 ERA-6SM
7	90.9	88.7	88.7	107	69.8	38.3	40.2	40.2	30.1
8	113	113	113	133	93.1	52.3	53.6	53.6	43.2
9	137	137	137	162	115	66.5	68.1	68.1	56.2
10	162	162	162	191	140	80.6	82.5	82.5	69.8
11	187	187	187	221	165	95.3	97.6	97.6	84.5
12	215	215	210	249	191	110	113	113	97.6
13	237	237	237	280	215	127	127	127	113
14	261	261	261	309	243	143	143	143	127
15	287	287	287	340	267	158	158	158	140
16	309	316	316	365	287	174	174	174	154
17	332	340	340	392	316	187	191	191	169
18	357	365	365	422	340	205	205	205	182
19	383	392	392	453	365	221	221	221	196
20	412	412	412	475	392	237	237	237	210

NSN GUIDE

MCL NO.	NSN
ERA-1SM	5962-01-459-9075
ERA-2SM	5962-01-459-7410
ERA-3SM	5962-01-459-9314

designers kits available

pin connections

PORT	cb
RF IN	1
RF OUT	3
DC	3
CASE GND	2,4
NOT USED	—

KIT NO.	Model Type	No. of Units in Kit	Description	Price \$ per kit
K1-ERA	ERA	30	10 of each 1,2,3	49.95
K2-ERA	ERA	20	10 of each 4,5	69.95
K1-ERASM	ERA-SM	30	10 of each 1SM, 2SM,3SM	49.95
K2-ERASM	ERA-SM	20	10 of each 4SM, 5SM	69.95
K3-ERASM	ERA-SM	30	10 of each 4SM, 5SM, 6SM	99.95



The Design Engineers Search Engine
Provides Actual Data Instantly
At: <http://www.minicircuits.com>

In Stock... Immediate Delivery
For Custom Versions Of Standard Models
Consult Our Applications Dept.

